

# SMART HEALTH MONITORING BASED ON ANDROID MOBILE DEVICES

V. RAJASHEKAR<sup>1</sup>, B. MANIKUMAR<sup>2</sup>

<sup>1</sup> Dept of ECE, Kasireddy Narayan Reddy College of Engineering and Research, Abdullapur, Hayathnagar Mandal, RANGAREDDY Dist, Telangana, India

<sup>2</sup> Guide Details, B.Manikumar, M.Tech, Associate professor, Kasireddy Narayan Reddy College of Engineering and Research, Abdullapur, Hayathnagar Mandal, RANGAREDDY Dist, Telangana, India

**Abstract:** We have developed an Android based mobile data acquisition (DAQ) solution, which collects personalized health information of the end-user, store analyze and visualize it on the smart device and optionally sends it towards to the datacenter for further processing. The smart mobile device is capable to collect information from a large set of various wireless (Bluetooth, and WiFi) and wired (USB) sensors. Embedded sensors of the mobile device provide additional useful status information (such as: user location, magnetic or noise level, acceleration, temperature, etc.). The user interface of our software solution is suitable for different skilled users, highly configurable and provides diary functionality to store information (about sleep problems, can act as a diet log, or even can be used as a pain diary). The software enables correlation analysis between the various sensor data sets. The developed system is tested successfully within our Living Lab facility. Sensor data acquisition on the personal mobile device enables both endusers and care givers to provide better and more effective health monitoring and facilitate prevention. The paper describes the internal architecture of the software solution and its main functionalities.

**Keywords:** *Microcontroller, Smart mobile device, Bluetooth, Wi-Fi, Sensors, Pulse Sensor*

## Introduction

The aging population of industrialized countries grows and this increases also among other things the health care costs. Transparently embedded remote

health care can become a new cost effective paradigm, which can solve most of the problems primarily centralized Health Care system's have. Currently, there is a large number of enabling technologies to measure the patient's physiological signals remotely. With handheld and PC devices used as data acquisition (DAQ) systems we are able to collect vital information about the (elderly and demented) patients remotely. Due to the different - in most cases proprietary and incompatible- sensor technologies and solutions, it is a hard task to create generic, user friendly DAQ systems. There are already remote patient monitoring solutions available such as the Android based MyFitnessCompanion, which is able to support the following therapy fields: Fitness, Diabetes, Asthma, Obesity, Hypertension, CHD, or the iCare[which provides medical guidance, emergency alarm functionality and collects personal health information. Other example is the Microsoft HealthVault which supports care of elderly persons (e.g.: neurodegenerative diseases, stroke etc.), additionally it provides online web interface to manage (process and share) health information. Biotech Lab at Obuda University is involved in AALAMSRK (a national R&D project), specialized both on Android based (we call this MobileHub) portable remote monitoring applications, and normal PC based (we call this HomeHub) remote monitoring solutions

## I. The Hardware System

**Micro controller:** This section forms the control unit of the whole project. This section basically consists of a Microcontroller with its associated circuitry like Crystal with capacitors, Reset circuitry, Pull up

resistors (if needed) and so on. The Microcontroller forms the heart of the project because it controls the devices being interfaced and communicates with the devices according to the program being written.

**ARM7TDMI:** ARM is the abbreviation of Advanced RISC Machines, it is the name of a class of processors, and is the name of a kind technology too. The RISC instruction set, and related decode mechanism are much simpler than those of Complex Instruction Set Computer (CISC) designs.

**Liquid-crystal display (LCD)** is a flat panel display, electronic visual display that uses the light modulation properties of liquid crystals. Liquid crystals do not emit light directly. LCDs are available to display arbitrary images or fixed images which can be displayed or hidden, such as preset words, digits, and 7-segment displays as in a digital clock. They use the same basic technology, except that arbitrary images are made up of a large number of small pixels, while other displays have larger elements.

## II. Design of Proposed Hardware System

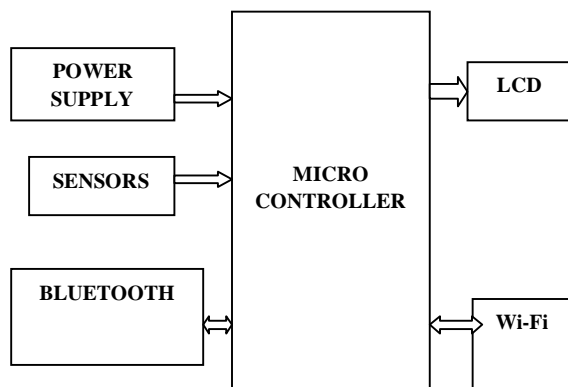

Fig.1.Block diagram

The process of working of this project is explained as follows. The total equipment of this project is placed inside a vehicle. Here we have GPS (Global

Positioning System) module by which we can get the location of the vehicle, the location values are displayed on the LCD (Liquid Crystal Display). In this project we have two sensors which are interfaced to the micro controller. Those are temperature sensor and CO sensor through which we can measure the temperature and amount of CO released from the vehicle. These values are also displayed on LCD. Here ADC (Analog to Digital Converter) is used to convert the analog data from the sensors to digital form. Whenever these values exceed the threshold then intimation is given to the RTA including vehicle's exact position

## IV.Board Hardware Resources Features

### *Temperature Sensor:*

The LM35 is an integrated circuit sensor that can be used to measure temperature with an electrical output proportional to the temperature (in °C)

The LM35 - An Integrated Circuit Temperature Sensor You can measure temperature more accurately than a using a thermistor. The sensor circuitry is sealed and not subject to oxidation, etc. The LM35 generates a higher output voltage than thermocouples and may not require that the output voltage be amplified.



It has an output voltage that is proportional to the Celsius temperature. The scale factor is .01V/°C The LM35 does not require any external calibration or trimming and maintains an accuracy of +/-0.4 °C at room temperature and +/- 0.8 °C over a range of 0 °C to +100 °C. Another important characteristic of the LM35DZ is that it draws only 60 micro amps from its supply and possesses a low self-heating capability. The sensor self-heating causes less than 0.1 °C

### **MEMS**

Micro electro mechanical systems (MEMS) are small integrated devices or systems that combine electrical and mechanical components. Their size range from the sub micrometer (or sub micron) level to the millimeter level and there can be any number, from a few to millions, in a particular system. MEMS extend the fabrication techniques developed for the integrated circuit industry to add mechanical elements such as beams, gears, diaphragms, and springs to devices.

Examples of MEMS device applications include inkjet-printer cartridges, accelerometers, miniature robots, microengines, locks, inertial sensors, micro transmissions, micromirrors, micro actuators, optical scanners, fluid pumps, transducers and chemical, pressure and flow sensors. Many new applications are emerging as the existing technology is applied to the miniaturization and integration of conventional devices.

These systems can sense, control and activate mechanical processes on the micro scale and function individually or in arrays to generate effects on the macro scale. The micro fabrication technology enables fabrication of large arrays of devices, which individually perform simple tasks, but in combination can accomplish complicated functions.

MEMS are not about any one application or device, or they are not defined by a single fabrication process or limited to a few materials. They are a fabrication approach that conveys the advantages of miniaturization, multiple components and microelectronics to the design and construction of integrated electromechanical systems. MEMS are not only about miniaturization of mechanical systems but they are also a new pattern for designing mechanical devices and systems.

#### ***Bluetooth:***

AUBTM-22 is a Bluetooth v1.2 module with SPP profiles. The module is intended to be integrated into

another HOST system which requires Bluetooth functions. The HOST system could send commands to AUBTM-22 through a UART. AUBTM-22 will parse the commands and execute proper functions, e.g. set the maximum transmit power, change the name of the module. And next the module can transmit the data receive from the uart with SPP profiles

#### ***Wifi***

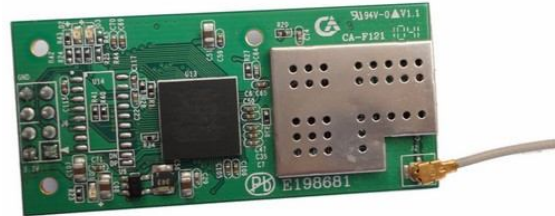

VSD03 is the new third-generation embedded Uart-Wifi modules studied by VSDTECH. Uart-Wifi is an embedded module based on the Uart serial, according with the WiFi wireless WLAN standards, It accords with IEEE802.11 protocol stack and TCP / IP protocol stack, and it enables the data conversion between the user serial and the wireless network module. through the Uart-Wifi module, the traditional serial devices can easily access to the wireless network. VSD03 does a comprehensive hardware and software upgrades based on the products of the first two generations, now it's more functional and more Convenient to use

#### **CONCLUSION**

During our almost 4 years long development period both the fixed and portable solutions have been rigorously tested in the LivingLab environment. Beside patient monitoring we had to monitor remotely not only the patient's status, but also some mobile hardware and software specific parameters (such as: battery level of sensors), and we had also to redesigned the whole user interface of the handheld device to support elderly persons with low IT skills. According to the received result both our PC and Android based DAQ solutions are capable to provide seamless remote monitoring of elderly persons not only at home, but with Mobile Hub also abroad. The developed solutions provide important feedbacks about health status to the patient and to the medical experts.



**REFERENCES**

[1] MyFitnessCompanion, <http://www.myfitnesscompanion.com/features.html> [Online, acc. 02.02.2012].

[2] Ziyu Lv, Feng Xia, Guowei Wu, Lin Yao, Zhikui Chen, iCare: A Mobile Health Monitoring System for the Elderly, The 3rd IEEE/ACM Int Conf on Cyber, Physical and Social Computing (CPSCom), IEEE, Hangzhou, China, December 18-20, 2010, arXiv:1011.3852v1

[3] Microsoft Health Vault, <http://www.microsoft.com/enus/healthvault/> [Online, acc. 01.02.2012].

[4] Proseniis- Innovation for healthier senior Age, <http://www.proseniis.hu/> [Online acc. 05.01.2012].

[5] Anders Wimo, Linus Jönsson, Anders Gustavsson; Cost of illness and burden of dementia in Europe - Prognosis to 2030, 27 October 2009, <http://www.alzheimereurope.org/OurResearch/EuropeanCollaboration-on-Dementia/Cost-of-dementia/Prognosis-to-2030>

[6] Intel® Health Guide PHS6000, Product Brief,

[ftp://download.intel.com/healthcare/pdf/Health\\_Guide\\_Brief.pdf](ftp://download.intel.com/healthcare/pdf/Health_Guide_Brief.pdf)

[7] Galaxy S specification, <http://www.samsung.com/uk/consumer/mobiledevices/smartphones/android/GT-I9000HKDXEU-spec>

[8] M. Kozlovsky, Zs. Meixner, G. Windisch, J. Márton, S. Ács, P. Bogdanov, A. Boruzs, P. Kotcauer, J. Ferenczi, V. Kozlovsky; Network and service management and diagnostics solution of a remote patient monitoring system, Lindi 2011 Conference, Budapest, Hungary

[9] M. Kozlovsky, J. Sicz-Mesziár, J. Ferenczi, J. Márton, G. Windisch, V. Kozlovsky, P. Kotcauer, A. Boruzs, P. Bogdanov, Zs. Meixner, K. Karóczkai, and S. Ács, Combined Health Monitoring and Emergency Management through Android Based Mobile Device for Elderly People; K.S. Nikita et al. (Eds.): MobiHealth 2011, LNICST 83, pp. 268–274, 2012. Institute for Computer Sciences, Social Informatics and Telecommunications Engineering 2012