

DESIGN AND IMPLEMENTATION OF AGRICULTURAL AUTOMATION SYSTEM THROUGH ZIGBEE AND GPRS

S. VENKATESWARLU¹, N.VASU²

¹ S. Venkateswarlu, Dept Of Ece, Sree Rama Engineering College, Tirupati, AP,India

² Guide Details, N.Vasu, M.Tech, Associate Professor, Sree Rama Engineering College, Tirupati, AP,India

Abstract: An automated irrigation system was developed to optimize water use for agricultural crops. The system has a distributed wireless network of soil-moisture and temperature sensors placed in the root zone of the plants. In addition, a gateway unit handles sensor information, triggers actuators, and transmits data to a web application. An algorithm was developed with threshold values of temperature and soil moisture that was programmed into a microcontroller-based gateway to control water quantity. The system was powered by photovoltaic panels and had a duplex communication link based on a cellular-Internet interface that allowed for data inspection and irrigation scheduling to be programmed through a web page. The automated system was tested in a sage crop field for 136 days and water savings of up to 90% compared with traditional irrigation practices of the agricultural zone were achieved. Three replicas of the automated system have been used successfully in other places for 18 months. Because of its energy autonomy and low cost, the system has the potential to be useful in water limited geographically isolated areas.

Keywords: *Microcontroller, GSM/GPRS Modem, LCD display, Temperature Sensor, Humidity Sensor, Water Level Sensor, Soil Sensor, Voltage Sensor, ZIGBEE module*

I. Introduction

Agriculture uses 85% of available freshwater resources worldwide, and this percentage will continue to be dominant in water consumption because of population growth and increased food demand. There is an urgent need to create strategies based on science and technology for sustainable use of water, including technical, agronomic, managerial, and institutional improvements. There are many systems to achieve water savings in various crops,

from basic ones to more technologically advanced ones. For instance, in one system plant water status was monitored and irrigation scheduled based on canopy temperature distribution of the plant, which was acquired with thermal imaging. In addition, other systems have been developed to schedule irrigation of crops and optimize water use by means of a crop water stress index (CWSI) [3]. The empirical CWSI was first defined over 30 years ago [4]. This index was later calculated

II. The Hardware System

Micro controller:

This section forms the control unit of the whole project. This section basically consists of a Microcontroller with its associated circuitry like Crystal with capacitors, Reset circuitry, Pull up resistors (if needed) and so on. The Microcontroller forms the heart of the project because it controls the devices being interfaced and communicates with the devices according to the program being written.

ARM7TDMI:

ARM is the abbreviation of Advanced RISC Machines, it is the name of a class of processors, and is the name of a kind technology too. The RISC instruction set, and related decode mechanism are much simpler than those of Complex Instruction Set Computer (CISC) designs.

Liquid-crystal display (LCD):

LCD is a flat panel display, electronic visual display that uses the light modulation properties of liquid crystals. Liquid crystals do not emit light directly. LCDs are available to display arbitrary images or fixed images which can be displayed or hidden, such

as preset words, digits, and 7-segment displays as in a digital clock. They use the same basic technology, except that arbitrary images are made up of a large number of small pixels, while other displays have larger elements.

III. Design of Proposed Hardware System

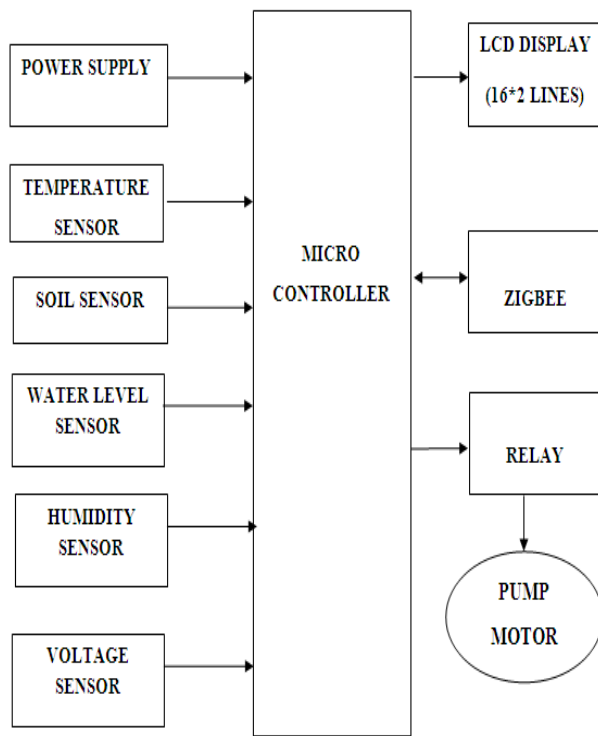

Fig.1.block diagram

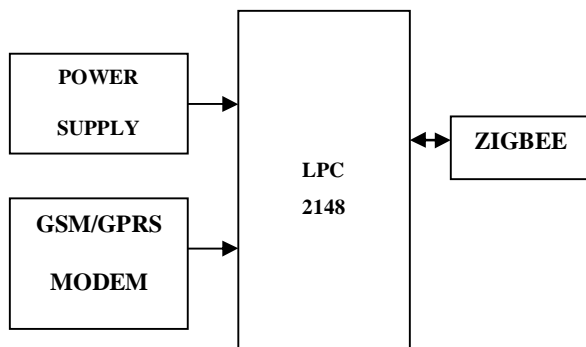

Fig.2.block diagram

In this paper, the development of the automated irrigation system based on microcontrollers and wireless communication at experimental scale within rural areas is presented. The aim of the implementation was to demonstrate that the automatic irrigation can be used to reduce water use. A microcontroller for data acquisition, and transceiver; the sensor measurements are transmitted to a microcontroller based receiver. This gateway permits the automated activation of irrigation when the threshold values of soil moisture and temperature is reached. Communication between the sensor nodes and the data receiver is via the Zigbee. This receiver unit also has a duplex communication link based on a cellular Internet interface, using General Packet Radio Service (GPRS) protocol, which is a packet oriented mobile data service cellular global system for mobile communications (GSM).

IV. Board Hardware Resources Features

Temperature Sensor:

Thermistors are thermally sensitive resistors whose prime function is to exhibit a large, predictable and precise change in electrical resistance when subjected to a corresponding change in body temperature. Negative Temperature Coefficient (NTC) thermistors exhibit a decrease in electrical resistance when subjected to an increase in body temperature and Positive Temperature Coefficient (PTC) thermistors exhibit an increase in electrical resistance when subjected to an increase in body temperature. U.S. Sensor produces thermistors capable of operating over the temperature range of -100° to over +600° Fahrenheit. Because of their very predictable characteristics and their excellent long term stability, thermistors are generally accepted to be the most advantageous sensor for many applications including temperature measurement and control.



Fig.3. Temperature Sensor

moisture monitoring, etc. For domestic applications, humidity control is required for living environment in buildings, cooking control for microwave ovens, etc. In all such applications and many others, **humidity sensors** are employed to provide an indication of the moisture levels in the environment.

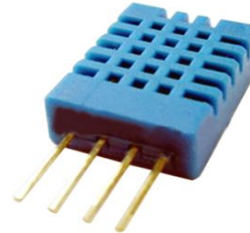

Fig.5. Humidity Sensor

Soil sensor:

The circuit designed uses a 5V supply, fixed resistance of 100Ω , variable resistance of $10K\Omega$, two copper leads as the sensor probes, 2N222N transistor. It gives a voltage output corresponding to the conductivity of the soil. The conductivity of soil depends upon the amount of moisture present in it. It increases with increase in the water content of the soil. The voltage output is taken at the transmitter which is connected to a variable resistance. This variable resistance is used to adjust the sensitivity of the sensor



Fig.4. Soil Sensor

Humidity Sensor:

Humidity is the presence of water in air. The amount of water vapor in air can affect human comfort as well as many manufacturing processes in industries. The presence of water vapor also influences various physical, chemical and biological processes. In agriculture, measurement of humidity is important for plantation protection (dew prevention), soil

Water level Sensor:

The purpose for this Sensor is to allow the user to evaluate a pressure sensor for not only water level sensing and to replace a mechanical switch, but also for water flow measurement, leak detection, and other solutions for smart appliances. This system continuously monitors water level and water flow

ZIGBEE:

ZIGBEE is a specification for a suite of high level communication protocols using small, low-power digital radios based on the IEEE 802.15.4-2003 standard for Low-Rate Wireless Personal Area Networks (LR-WPANs), such as wireless light switches with lamps, electrical meters with in-home-displays, consumer electronics equipment via short-range radio needing low rates of data transfer. The technology defined by the ZIGBEE specification is intended to be simpler and less expensive than other WPANs, such as Bluetooth. ZIGBEE is targeted at radio-frequency (RF) applications that require a low data rate, long battery life, and secure networking.

ZIGBEE is a low-cost, low-power, wireless mesh networking standard. First, the low cost allows the technology to be widely deployed in wireless control and monitoring applications. Second, the low power-usage allows longer life with smaller batteries. Third, the mesh networking provides high reliability and more extensive range.

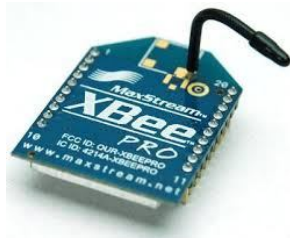

Fig.6.ZIGBEE Module



V. CONCLUSION

The automated irrigation system implemented was found to be feasible and cost effective for optimizing water resource for agricultural production. This irrigation system allows cultivation in places with water scarcity thereby improving sustainability. The automated irrigation system developed proves that the use of water can be diminished for a given amount of fresh biomass production. The use of solar power in this irrigation system is pertinent and significantly important for organic crops and other agricultural products that are geographically insolated, where the investment in electric power supply would be expensive. The irrigation system can be adjusted to a variety of specific crop needs and requires minimum maintenance. The modular configuration of the automated irrigation system allows it to be scaled up for larger greenhouses or open fields. In addition, other applications such as temperature monitoring in compost production can be easily implemented. The Internet controlled duplex communication system provides a powerful decision making device concept for adaptation to several cultivation scenarios. Furthermore, the Internet link allows the supervision through mobile telecommunication devices, such as a smart phone. Besides the monetary savings in water use, the importance of the preservation of this natural resource justify the use of this kind of irrigation systems.

VI. REFERENCES

- [1] W. A. Jury and H. J. Vaux, "The emerging global water crisis: Managing scarcity and conflict between water users," *Adv. Agronomy*, vol. 95, pp. 1–76, Sep. 2007.
- [2] X. Wang, W. Yang, A. Wheaton, N. Cooley, and B. Moran, "Efficient registration of optical and IR



- images for automatic plant water stress assessment," *Comput. Electron. Agricult.*, vol. 74, no. 2, pp. 230–237, Nov. 2010.
- [3] G. Yuan, Y. Luo, X. Sun, and D. Tang, "Evaluation of a crop water stress index for detecting water stress in winter wheat in the North China Plain," *Agricult. Water Manag.*, vol. 64, no. 1, pp. 29–40, Jan. 2004.
- [4] S. B. Idso, R. D. Jackson, P. J. Pinter, Jr., R. J. Reginato, and J. L. Hatfield, "Normalizing the stress degree day parameter for environmental variability," *Agricult. Meteorol.*, vol. 24, pp. 45–55, Jan. 1981.
- [5] Y. Erdem, L. Arin, T. Erdem, S. Polat, M. Deveci, H. Okursoy, and H. T. Gültas, "Crop water stress index for assessing irrigation scheduling of drip irrigated broccoli (*Brassica oleracea* L. var. *italica*)," *Agricult. Water Manag.*, vol. 98, no. 1, pp. 148–156, Dec. 2010.
- [6] K. S. Nemali and M. W. Van Iersel, "An automated system for controlling drought stress and irrigation in potted plants," *Sci. Horticult.*, vol. 110, no. 3, pp. 292–297, Nov. 2006.
- [7] S. A. O'Shaughnessy and S. R. Evett, "Canopy temperature based system effectively schedules and controls center pivot irrigation of cotton," *Agricult. Water Manag.*, vol. 97, no. 9, pp. 1310–1316, Apr. 2010.
- [8] R. G. Allen, L. S. Pereira, D. Raes, and M. Smith, *Crop Evapotranspiration—Guidelines for Computing Crop Water Requirements—FAO Irrigation and Drainage Paper 56*. Rome, Italy: FAO, 1998.
- [9] S. L. Davis and M. D. Dukes, "Irrigation scheduling performance," *Agricult. Water Manag.*, vol. 98, no. 1, pp. 19–28, Dec. 2010.
- [10] K. W. Migliaccio, B. Schaffer, J. H. Crane, and F. S. Davies, "Plant response to evapotranspiration and soil water sensor irrigation scheduling methods for papaya production in south Florida," *Agricult. Water Manag.*, vol. 97, no. 10, pp. 1452–1460, Oct. 2010.
- [11] J. M. Blonquist, Jr., S. B. Jones, and D. A. Robinson, "Precise irrigation scheduling for turfgrass using a subsurface electromagnetic soil moisture sensor," *Agricult. Water Manag.*, vol. 84, nos. 1–2, pp. 153–165, Jul. 2006.
- [12] O. M. Grant, M. J. Davies, H. Longbottom, and C. J. Atkinson, "Irrigation scheduling and irrigation systems: Optimising irrigation efficiency for container ornamental shrubs," *Irrigation Sci.*, vol. 27, no. 2, pp. 139–153, Jan. 2009.
- [13] Y. Kim, R. G. Evans, and W. M. Iversen, "Remote sensing and control of an irrigation system using a distributed wireless sensor network," *IEEE Trans. Instrum. Meas.*, vol. 57, no. 7, pp. 1379–1387, Jul. 2008.
- [14] Y. Kim and R. G. Evans, "Software design for wireless sensor-based site-specific irrigation," *Comput. Electron. Agricult.*, vol. 66, no. 2, pp. 159–165, May 2009.
- [15] D. K. Fisher and H. A. Kebede, "A low-cost microcontroller-based system to monitor crop temperature and water status," *Comput. Electron. Agricult.*, vol. 74, no. 1, pp. 168–173, Oct. 2010.
- [16] Y. Kim, J. D. Jabro, and R. G. Evans, "Wireless lysimeters for realtime online soil water monitoring," *Irrigation Sci.*, vol. 29, no. 5, pp. 423–430, Sep. 2011.
- [17] O. Mirabella and M. Brischetto, "A hybrid wired/wireless networking infrastructure for greenhouse management," *IEEE Trans. Instrum. Meas.*, vol. 60, no. 2, pp. 398–407, Feb. 2011.
- [18] I. F. Akyildiz, W. Su, Y. Sankarasubramaniam, and E. Cayirci, "A survey on sensor networks," *IEEE Commun. Mag.*, vol. 40, no. 8, pp. 104–112, Aug. 2002.
- [19] J. Yick, B. Mukherjee, and D. Ghosal, "Wireless sensor network survey," *Comput. Netw.*, vol. 52, no. 12, pp. 2292–2330, Aug. 2008.
- [20] M. Winkler, K.-D. Tuchs, K. Hughes, and G. Barclay, "Theoretical and practical aspects of military wireless sensor networks," *J. Telecommun. Inf. Technol.*, vol. 2, pp. 37–45, Apr./Jun. 2008.



- [21] M. P. Durisic, Z. Tafa, G. Dimic, and V. Milutinovic, "A survey of military applications of wireless sensor networks," in Proc. MECO, Jun. 2012, pp. 196–199.
- [22] M. C. Rodríguez-Sánchez, S. Borromeo, and J. A. Hernández-Tamames, "Wireless sensor networks for conservation and monitoring cultural assets," IEEE Sensors J., vol. 11, no. 6, pp. 1382–1389, Jun. 2011.
- [23] G. López, V. Custodio, and J. I. Moreno, "LOBIN: E-textile and wireless-sensor-network-based platform for healthcare monitoring in future hospital environments," IEEE Trans. Inf. Technol. Biomed., vol. 14, no. 6, pp. 1446–1458, Nov. 2010.
- [24] J. M. Corchado, J. Bajo, D. I. Tapia, and A. Abraham, "Using heterogeneous wireless sensor networks in a telemonitoring system for healthcare," IEEE Trans. Inf. Technol. Biomed., vol. 14, no. 2, pp. 234–240, Mar. 2010.
- [25] G. X. Lee, K. S. Low, and T. Taher, "Unrestrained measurement of arm motion based on a wearable wireless sensor network," IEEE Trans. Instrum. Meas., vol. 59, no. 5, pp. 1309–1317, May 2010.